

# Proposal to Flexible PCB Materials

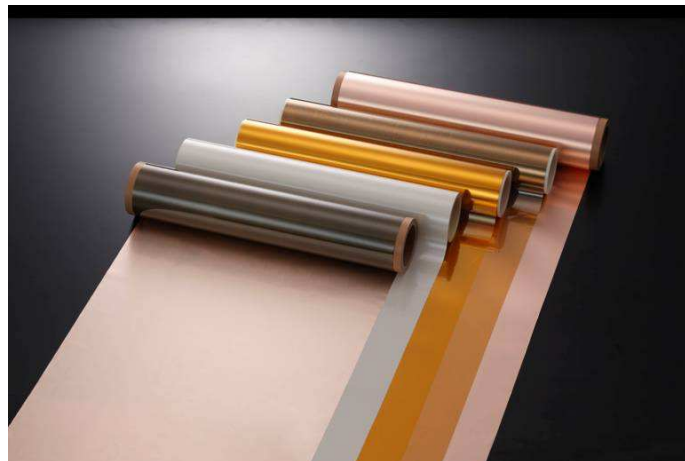

**FELIOS**

**June, 2008**



# Core Technology

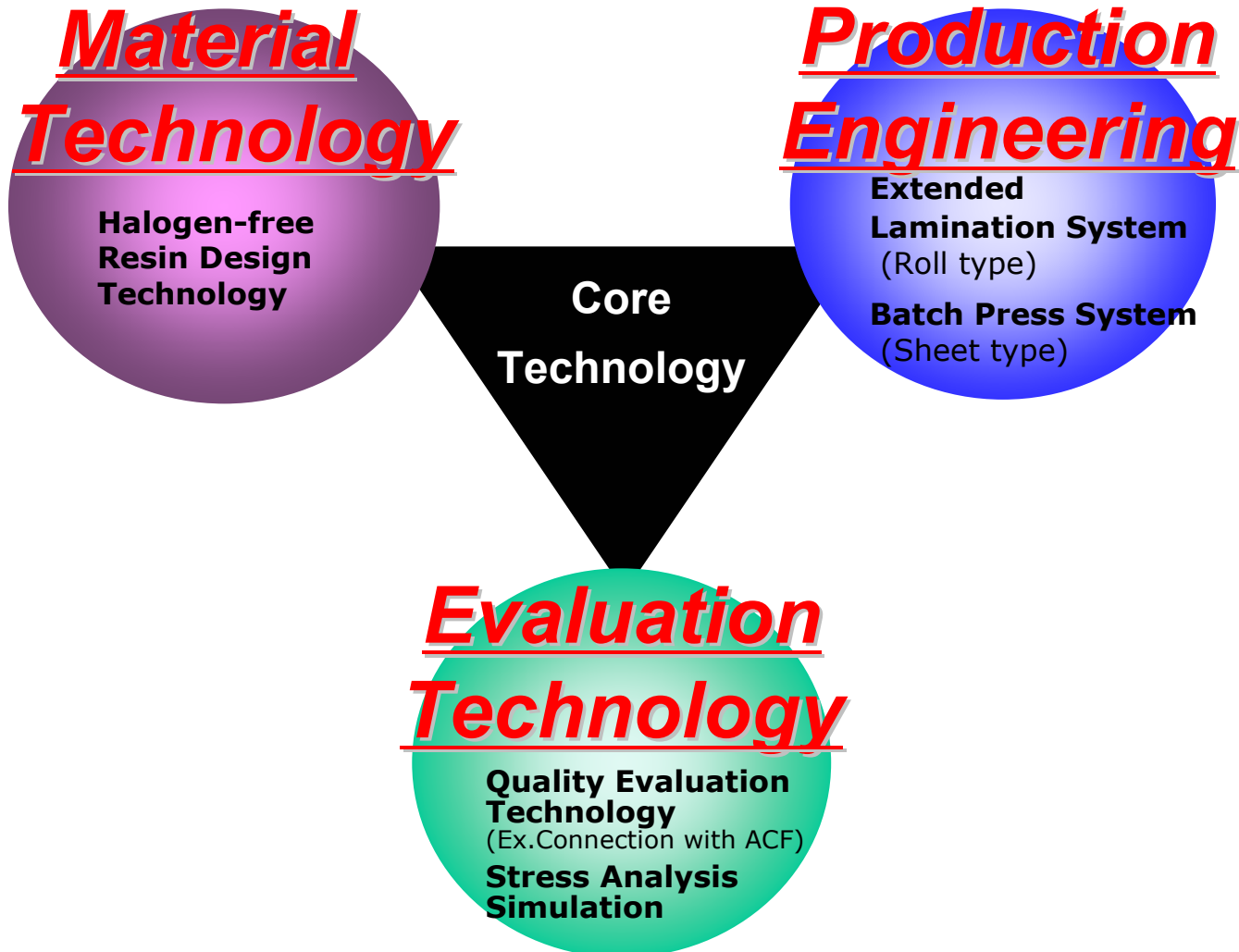

# FPC Material Marketing Strategy

## FPC Users

- **Focus Application**
- **Evaluation Technology**  
(Ex; Bending test method cooperative development with customer and OEM)

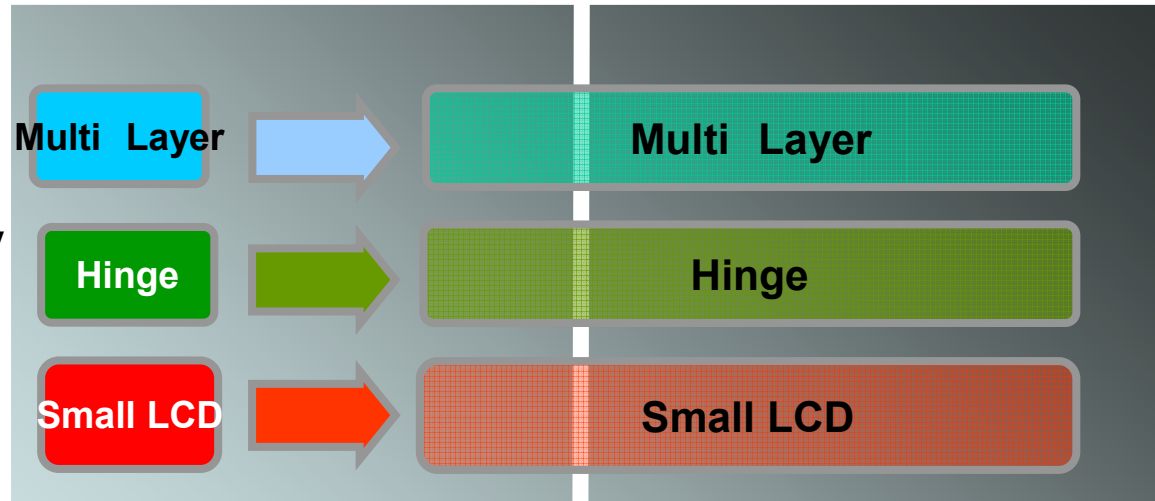

## Rigid Flex Users

- **Total Solution**  
(All HF Materials -Rigid & FCCL)
- **Existing Sales Channel**

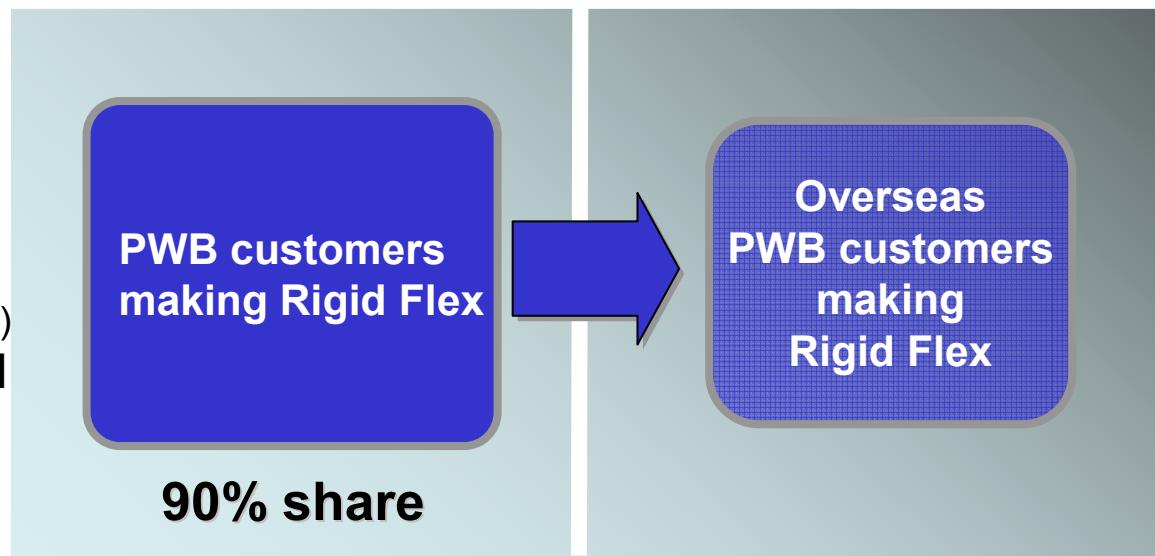

**Japan**

**Non Japan**

Matsushita Electric Works, Ltd.

# Production Capacity

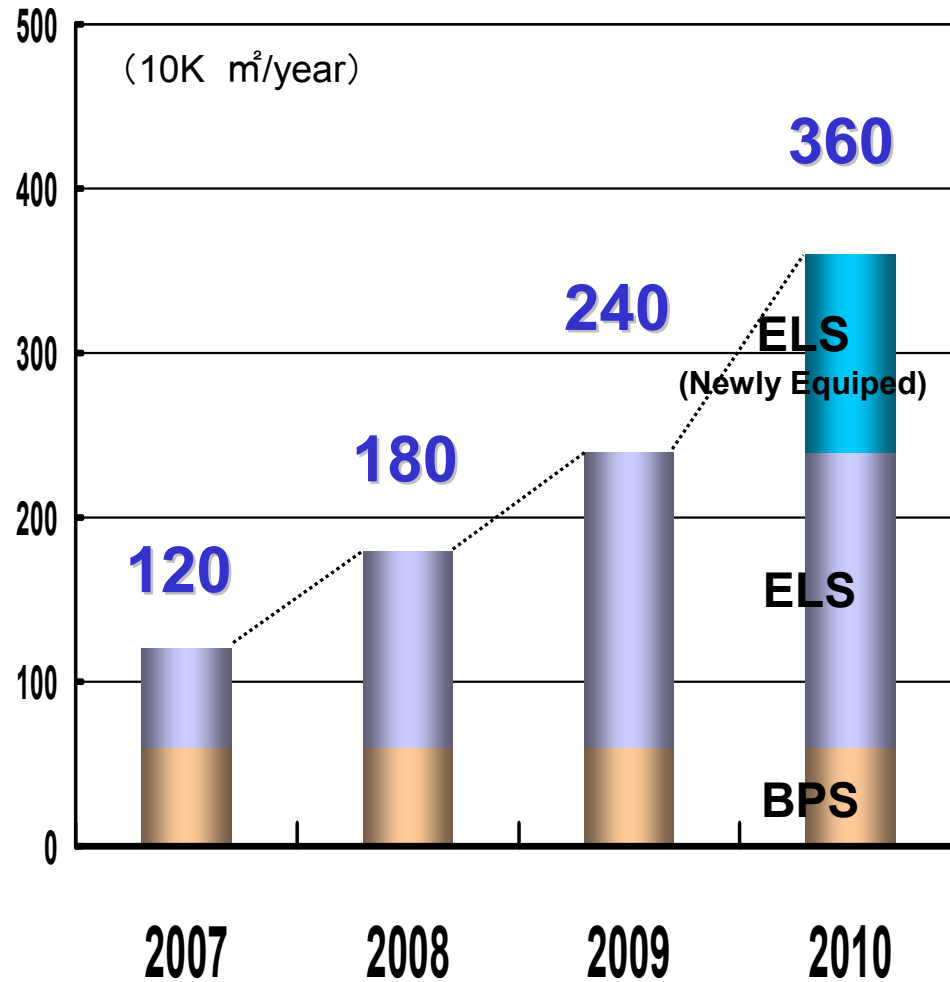

**Yokkaichi**



- 1. Roll Style
- 2. ELS

**Koriyama**



- 1. Sheet Style
- 2. BPS



# ISO & Environmental Friendly

## ■ ISO

【Koriyama Factory】	ISO9001	April 2005
	ISO14000	April 2005
	TS16949	May 2007
【Yokkaichi Factory】	ISO9001	August 2006
	ISO14000	February 2007
	TS16949	March 2007

## ■ Environmental Friendly



**FELIOS**

**All Halogen Free Type**

eco  
ideas

## 2Layer FCCL (Adhesiveless type)

R-F775,770: Polyimide (Upilex)

**New** R-F785,780: Polyimide (Pixeo)

**New** R-F705,700: LCP (Vecstor)

### ELS

(Extended Lamination System)

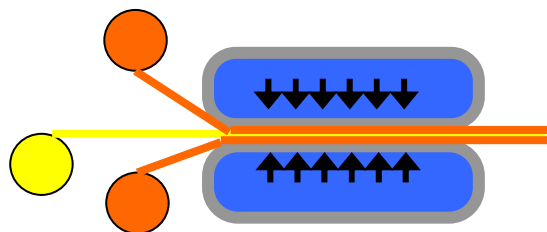

### BPS

(Batch Press System)

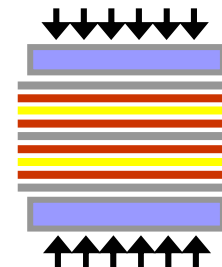

# Panasonic ELS (Extended Lamination System)

## Feature of Panasonic ELS

- **Stable Quality**
  - Uniform lamination by pressing with large area
  - <Class100 clean environment in ELS processing
- **ELS with various kinds of Films and Copper foils**

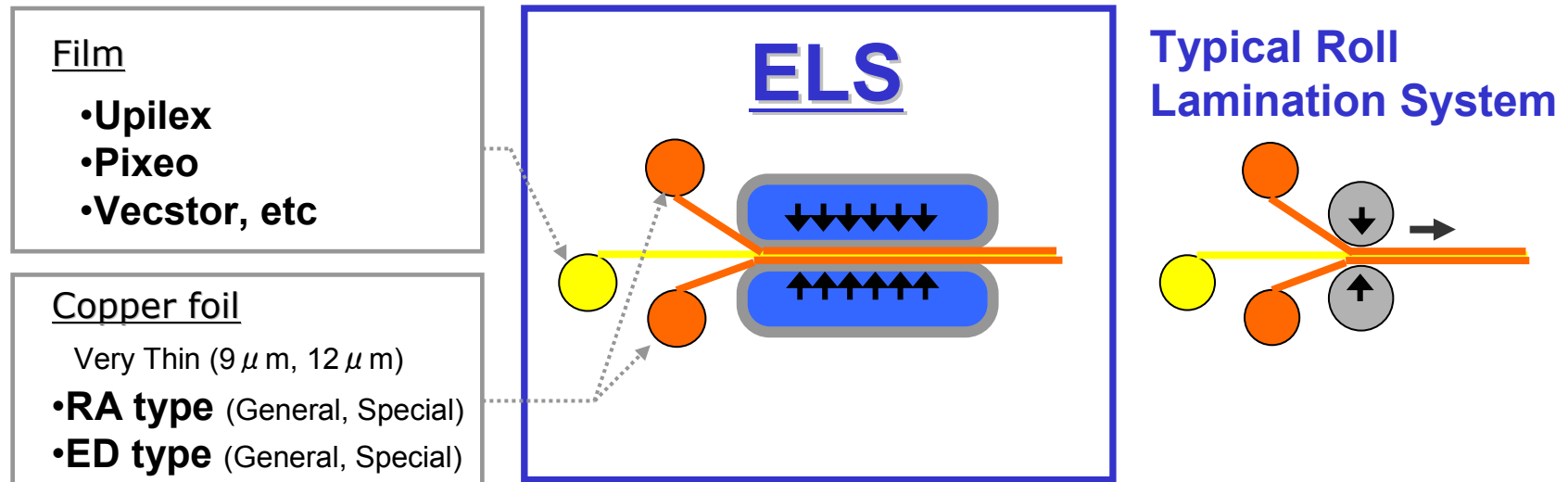

# Excellent Dimensional Stability

## 14 $\mu$ m PI based FCCL (R-F785F)

• Copper=Special RA 18  $\mu$  m    • Test method :IPC-TM-650

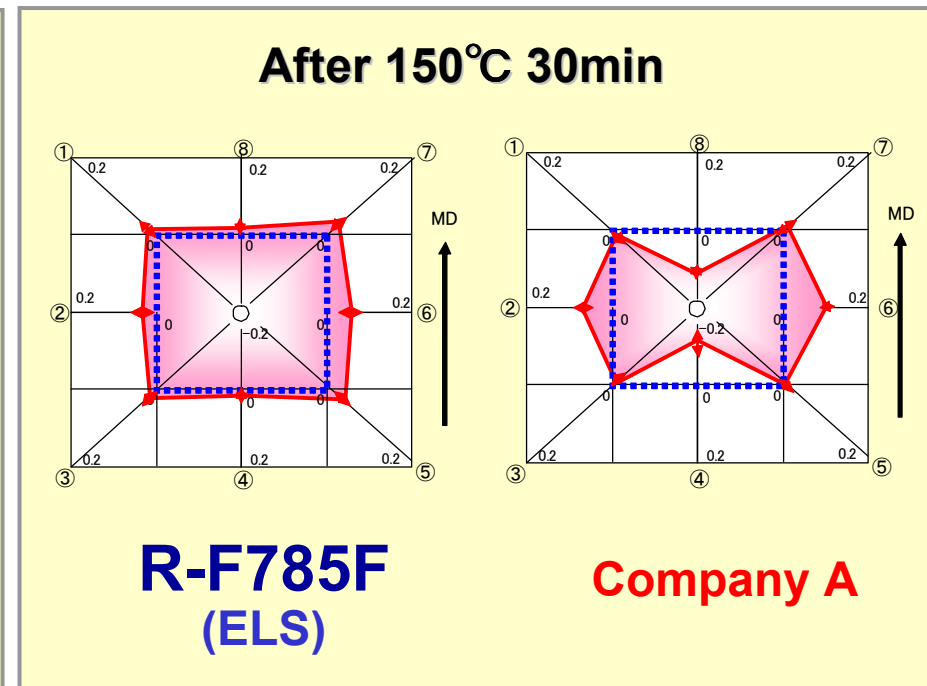
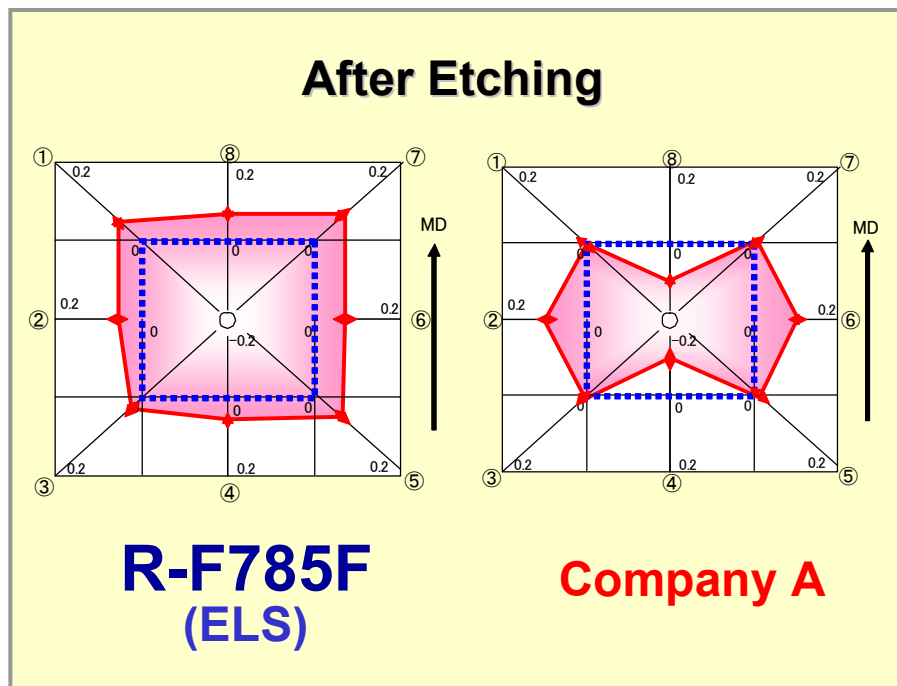

# Excellent Dimensional Stability

## 14 $\mu$ m PI based FCCL (R-F785F)

·Copper=Special RA 18  $\mu$  m    ·Test method :IPC-TM-650

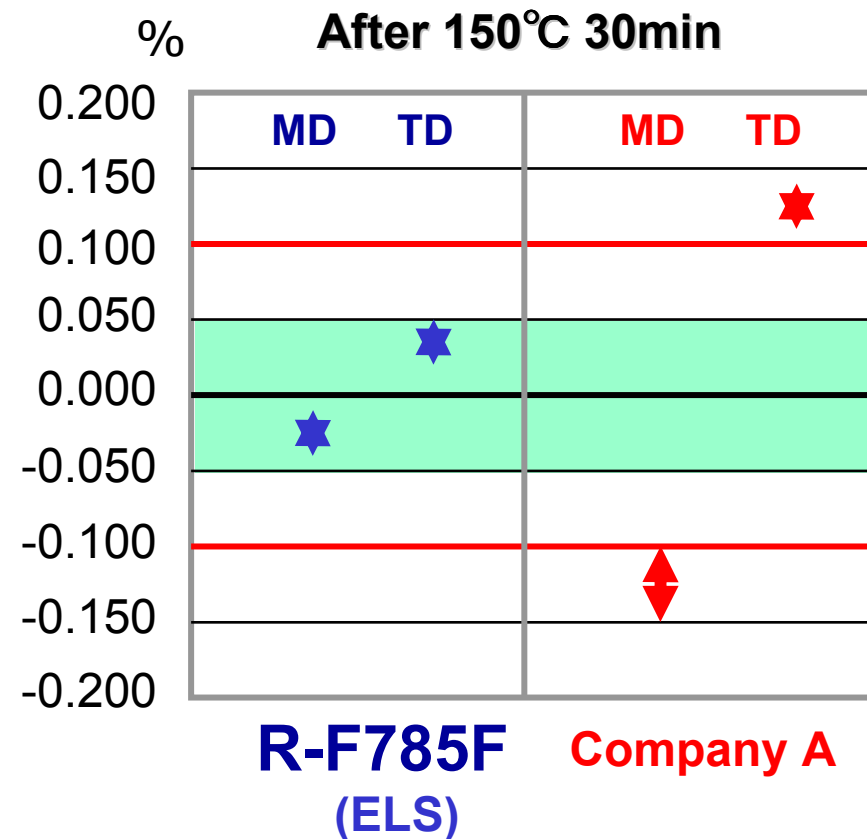
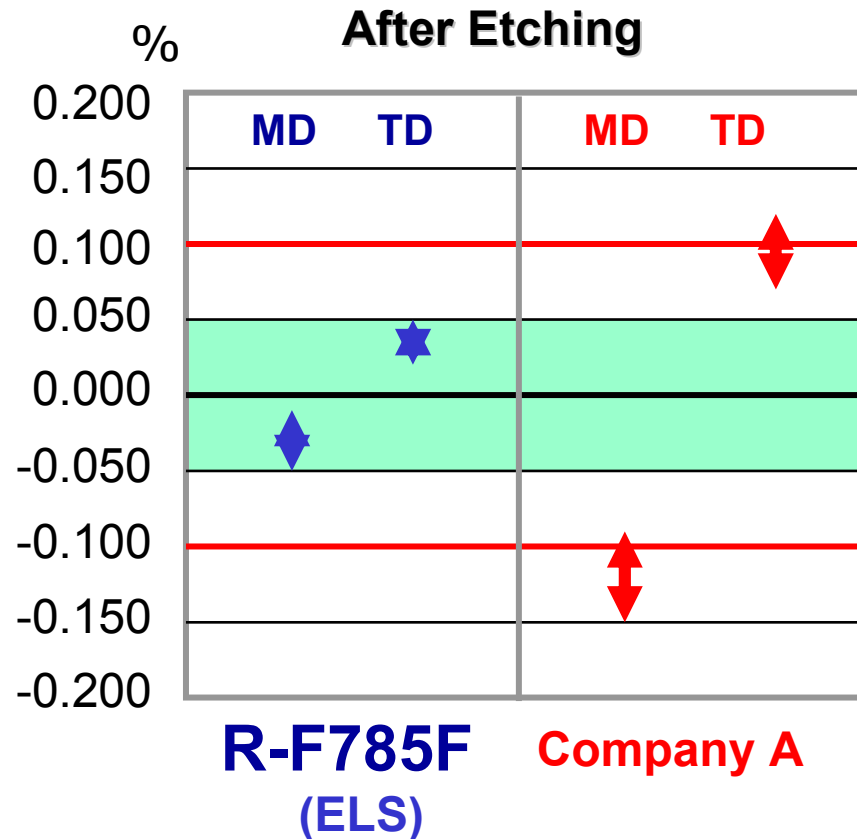

# Product Offering Availability

## ■ Part Number

Double Sided	Single Sided
R-F775	R-F770
<b>R-F785</b>	<b>R-F780</b>

**New**

## Polyimide Thickness

14 $\mu$	18 $\mu$	20 $\mu$	25 $\mu$	50 $\mu$
-	-	○	○	○
○	○	-	-	-

## Product Size

Type	TD (width)
Roll	250mm 500mm, 510mm
Sheet	Max 510mm

## Copper foil

	9 $\mu$ m (1/4oz)	12 $\mu$ m (1/3oz)	18 $\mu$ m (1/2oz)	35 $\mu$ m (1oz)
ED	○	○	○	-
RA	○	○	○	○

# New Product: LCP based FCCL (Liquid Crystal Polymer)

## R-F705

### General Properties

Property	Test Condition	Unit	R-F705 LCP50 μ m, Cu18 μ	R-F775 PI25 μ m, Cu18 μ	Test Method
Surface Resistivity	A	Ω	4.9E+14	4.0E+13	JIS C6471
Dielectric Constant (Dk)	A 2GHz	-	3.0	3.2	IPC-TM650 Method2.5.5.5
	A 10GHz		3.0	3.2	
Dissipation Factor (Df)	A 2GHz	-	0.0008	0.0015	IPC-TM650 Method2.5.5.5
	A 10GHz		0.0016	0.0027	
Moisture Absorption	25°C/50h dipping	%	0.04	1.0	-
Peel Strength	A	N/m m	0.8	1.7	IPC-TM-650
	260°C Solder for 5 sec				
Frame Resistant (UL)	A and E-168/70	-	94VTM-0	94V-0	-
Chemical Resistance	HCl 2mol/l 23°C for 5min	-	No abnormality	No abnormality	JIS C6471
	NaOH 2mol/l 23°C for 5 min				
	IPA 23°C for 5 min				
Solder Heat Resistance	260°C solder float for 1 min	-	No abnormality	No abnormality	Internal Method
	288°C solder float for 1 min	-	No abnormality	No abnormality	
Water Absorption Solder Heat Resistance	C-96/40/90	-	No abnormality	No abnormality	Internal Method
	260°C solder float for 1 min				
Dimensional Stability	After etching (MD direction)	%	0.001	-0.007	IPC-TM650
	After etching (TD direction)		-0.005	0.016	
	E-0.5/150 (MD direction)		0.014	-0.023	
	E-0.5/150 (TD direction)		0.019	0.000	

Note) The above data are our actual values and not assured values.

**Confidential**

Matsushita Electric Works, Ltd.

# Classification of CCL

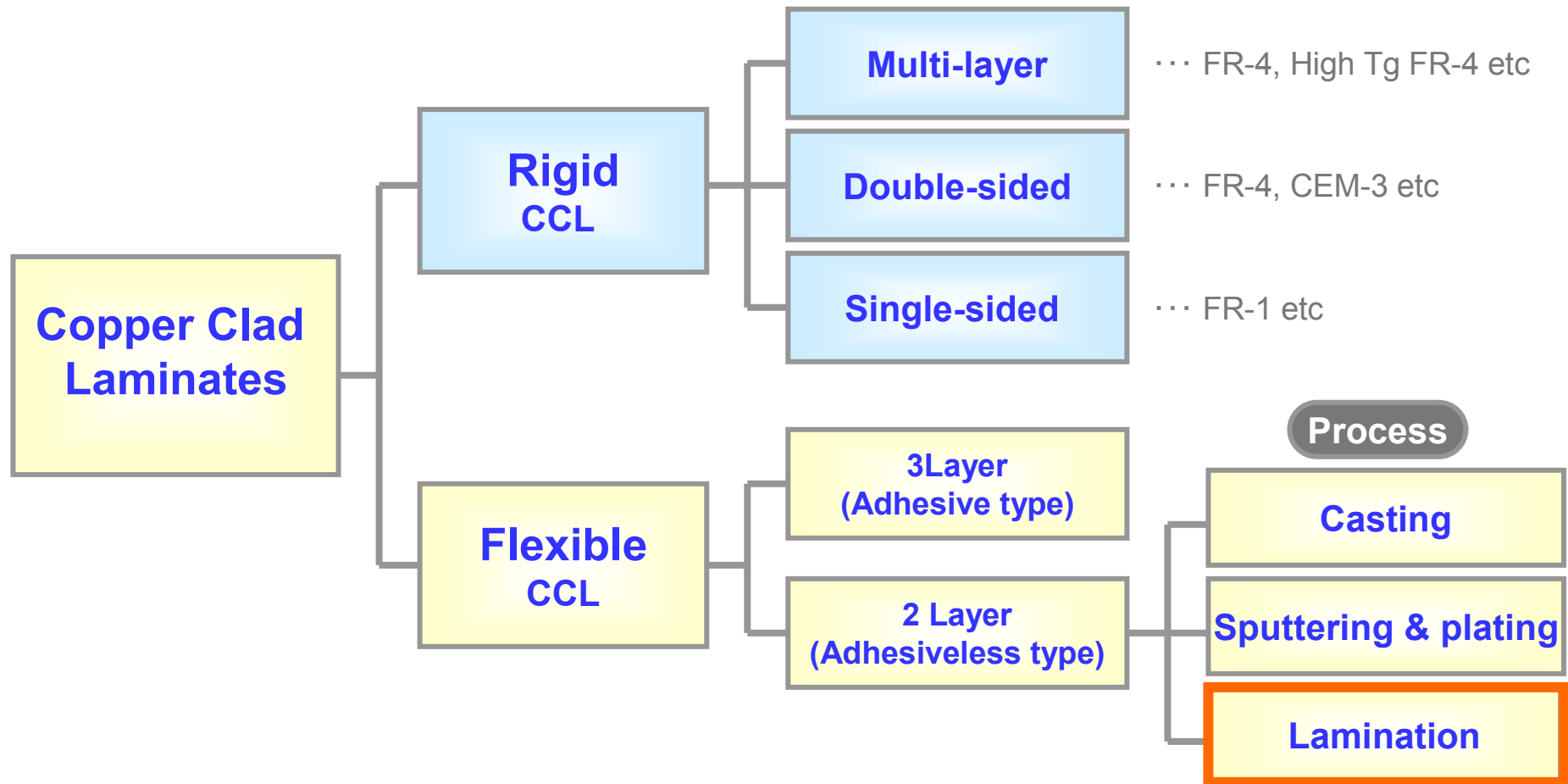

# Comparison in 2Layer FCCL

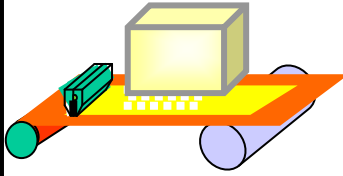
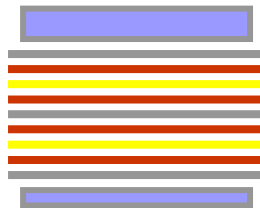
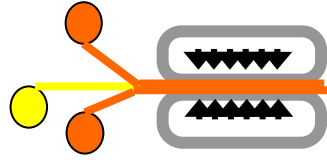
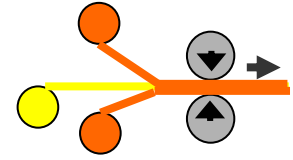
Property	Casting (Roll Lamination)	Batch Press	ELS	Typical Roll Lamination
				
Dimension Stability	Good	Excellent	Excellent	Inferior
Thin Copper	Difficulty	Good	Excellent	Difficulty
Thin PI	Excellent	Good	Excellent	Excellent
Quick Turn/Small Batch	Impossible	Excellent	Difficulty	Difficulty
Double side Cost	Inferior	Excellent	Excellent	Excellent
Single side cost	Excellent	-	Good	Good
Manufacturer	<p>Dupont</p> <p>Nippon Steel</p>	<p><b>Panasonic</b></p>		<p>Arisawa</p> <p>Mitsui</p>